

tekmar® - Data Brochure

Relay 003 — 24Vac Coil

Relay 004 — 120Vac Coil



D 003
12/93

Relay 003 – 24Vac Coil

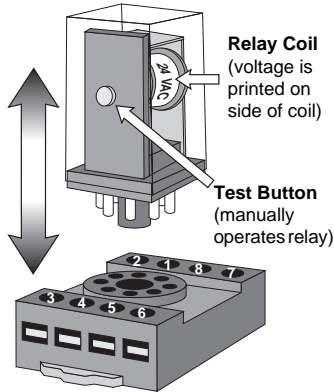

Relay Coil
(voltage is printed on side of coil)

Test Button
(manually operates relay)

Relay Base

Relay pulls straight out of base. Base can be pre-wired and wiring can be tested before plugging in relay. Relay can be replaced without disturbing the wiring.

Mechanical Installation

The Relay base can be mounted directly to a flat surface, or onto a standard TS35 DIN rail.

Wiring connections are made at the base terminals and are checked with the relay unplugged.

Relay 003 plugs directly into its base.

Pushing the test button on the side of the relay will manually close the N.O. (Normally Open) contacts and open the N.C. (Normally Closed) contacts.

Electrical Installation

The Relay contacts are rated for a maximum current of:

- 10A resistive 10A inductive at 120Vac, 1/3 hp,
- 10A resistive 7A inductive at 250Vac,
- 10A resistive 2A inductive at 28Vdc.

24Vac. is required to energize the relay coil.

Operation

When 24Vac is applied to terminals 2 & 7, the coil is energized and the N.O. (Normally Open) contacts will close at the same time as the N.C. (Normally Closed) contacts open. When the 24Vac is removed, the spring will automatically return the relay contacts to the power-down position.

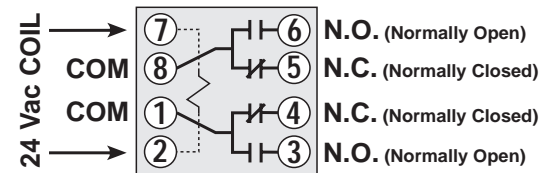

All tekmar wiring diagrams show relays in the power-down condition as illustrated above. When the coil is energized, the relay will switch its contacts as illustrated in the two diagrams below.

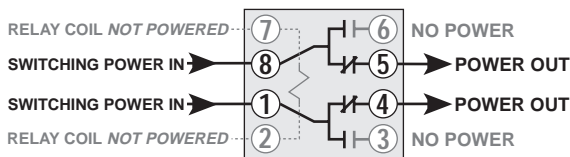

Relay 003 with no power to coil.

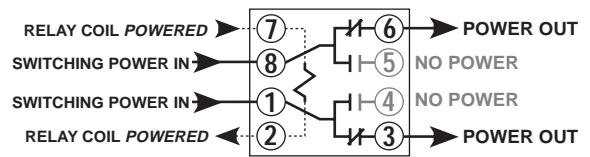

Relay 003 with power to coil.

Relay 004 – 120Vac Coil

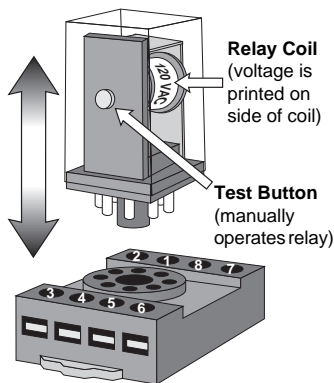

Relay Coil
(voltage is printed on side of coil)

Test Button
(manually operates relay)

Relay Base

Relay pulls straight out of base. Base can be pre-wired and wiring can be tested before plugging in relay. Relay can be replaced without disturbing the wiring.

Mechanical Installation

The Relay base can be mounted directly to a flat surface, or onto a standard TS35 DIN rail.

Wiring connections are made at the base terminals and are checked with the relay unplugged.

Relay 004 plugs directly into its base.

Pushing the test button on the side of the relay will manually close the N.O. (Normally Open) contacts and open the N.C. (Normally Closed) contacts.

Electrical Installation

The Relay contacts are rated for a maximum current of:

- 10A resistive 10A inductive at 120Vac, 1/3 hp,
- 10A resistive 7A inductive at 250Vac,
- 10A resistive 2A inductive at 28Vdc.

120Vac. is required to energize the relay coil.

Operation

When 120Vac is applied to terminals 2 & 7, the coil is energized and the N.O. (Normally Open) contacts will close at the same time as the N.C. (Normally Closed) contacts open. When the 120Vac is removed, the spring will automatically return the relay contacts to the power-down position.

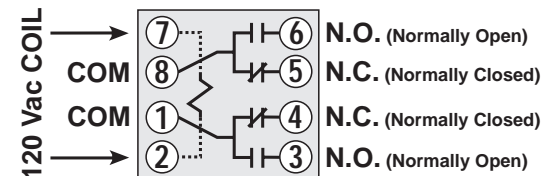

All tekmar wiring diagrams show relays in the power-down condition as illustrated above. When the coil is energized, the relay will switch its contacts as illustrated in the two diagrams below.

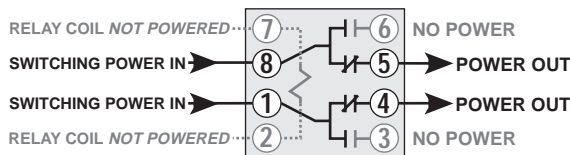

Relay 004 with no power to coil.

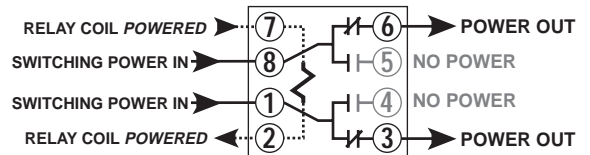

Relay 004 with power to coil.

Typical Applications

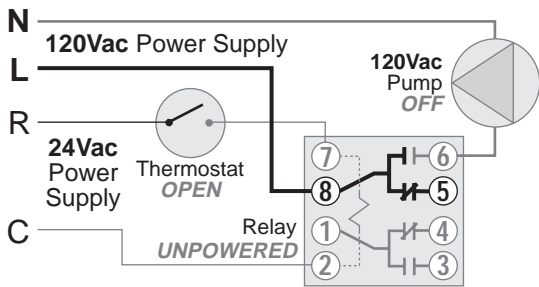

A low voltage thermostat energizes Relay 003 to turn on a 120Vac zone pump.

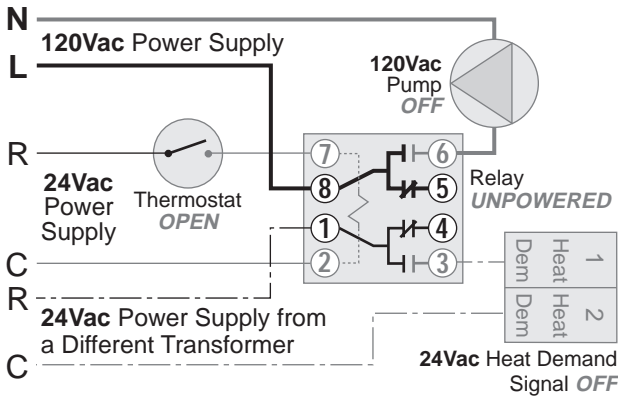
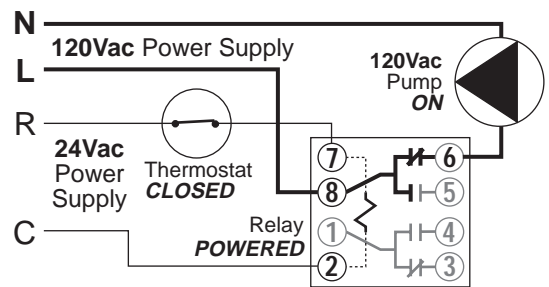

A low voltage thermostat energizes Relay 003 to turn on a 120Vac zone pump and deliver a Heat Demand signal to a tekmar Reset Control.

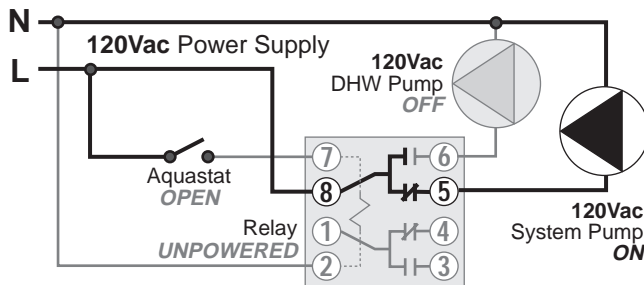
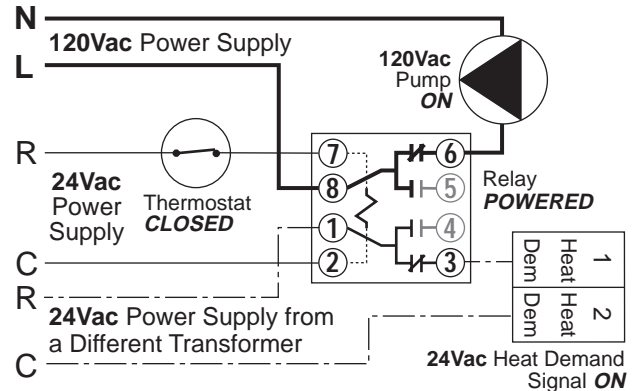

A 120Vac Aquastat energizes Relay 004 to Switch between the System and DHW pumps for DHW priority.

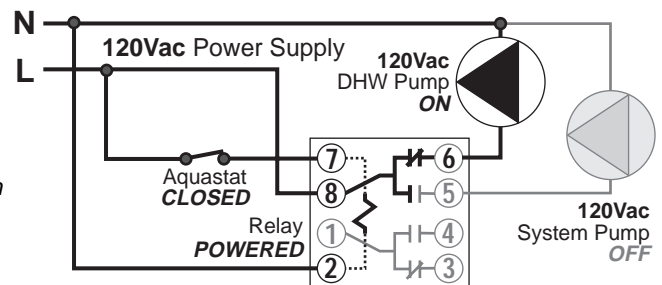

Limited Warranty and Product Return Procedure

Limited Warranty: tekmar warrants to the original purchaser each tekmar product against defects in workmanship and materials when the product is installed and used in compliance with tekmar's instructions. This limited warranty covers the cost of parts and labour provided by tekmar to correct defects in materials and/or workmanship. Returned products that are fully operational are not considered a warranty case. tekmar also does not cover parts or labour to remove, transport or reinstall a defective product. tekmar will not be liable for any damage other than repair or replacement of the defective part or parts and such repair or replacement shall be deemed to be the sole remedy from tekmar. This warranty shall not apply to any defects caused or repairs required as a result of unreasonable or negligent use, neglect, accident, improper installation, or unauthorised repair or alterations. In case of defect, malfunction or failure to conform to warranty, tekmar will, for a warranty period of 24 months from the date of invoice to the original purchaser or 12 months from the date of installation of the product, whichever occurs first, repair, exchange or give credit for the defective product. Any express or implied warranty which the purchaser may have, including merchantability and fitness for a particular purpose, shall not extend beyond 24 months from the date of invoice or 12 months from the date of installation of the product, whichever occurs first.

Replacements: tekmar can send replacement products if requested. All replacements are invoiced. Any possible credit for the replacement will only be issued once the replaced product has been returned to tekmar.

Product Return Procedure: Products that are believed to have failed must be returned to tekmar Control Systems Ltd. 4611-23rd Street, Vernon B.C. Canada V1T 4K7 when agreed to by tekmar. The installer or other qualified service person must, at the owner's expense, determine which component has failed. The product must be returned complete with all of its components (sensors, base, etc.).

Products must be returned together with the proof of purchase to the original purchaser who then returns the product to tekmar after receiving a Return Goods Authorisation (RGA) number from tekmar.

Please include the following information with the product: The full address of the original purchaser, the RGA number and a description of the problem.

From the U.S.A., in order to avoid customs charges, products must be returned via US Post with the package clearly marked with the RGA number, product type and the statement "Canadian Product returned for repair". For shipping purposes the product can be valued at one half list price.

- 1) If returned during the warranty period and the product is defective, tekmar will issue full credit for the returned product less cost of missing parts.
- 2) If returned during the warranty period and the product is fully operational, tekmar will return the product to the original purchaser for a testing cost of \$30.00 plus postage.
- 3) If returned during the warranty period and the product is not damaged and is fully operational, tekmar can take back the product for a return charge of 40% of the product's net value. This request has to be specified otherwise the product will be returned with a testing cost of \$30.00 plus postage.
- 4) If returned after the warranty period and the product needs repair, tekmar will repair and return the product. Repair and postage costs will be invoiced. tekmar's repair costs are calculated at \$30.00 / hour plus the cost of parts. If the repair costs will be more than \$60.00 a repair estimate will be sent to the original purchaser.

In North America: tekmar Control Systems Ltd., Canada
tekmar Control Systems, Inc., USA
Head office: 4611 - 23rd Street
Vernon, B.C. Canada V1T 4K7
Tel. (604) 545-7749 Fax. (604) 545-0650

