

Table of Contents

Display Operation	pg 1	Menus	pg 6
General	pg 1	Error Messages	pg 7
Sequence of Operation	pg 2	Technical Data	pg 8
Installation	pg 3	Warranty	pg 8
Wiring.....	pg 4		

Display / Keypad Operation

The thermostat's display has four distinct fields. These fields are the **Menu** field, the **Item** field, the **Number** field and the **Status** field. The four buttons on the face of the thermostat are used to navigate through the menus and items to view and / or adjust the desired settings.

Menu Field
Displays the current menu

Item Field
Displays an abbreviated name of the selected item

Number Field
Displays the current value of the selected item

Status Field
Displays the current status of the thermostat's inputs, outputs and operation

Buttons
Selects Menus, Items and adjusts settings

Display Symbols

- Warning**
Displays when an error exists.
- Access Level (508 Only)**
Displays when in the user access level.
- Heat One**
Displays when the heat contact is on.

General

CYCLES PER HOUR

The thermostat operation is based on cycles per hour. The number of cycles per hour is adjustable through the HEAT CYC setting in the *Adjust* menu. During each cycle that heating is required, the thermostat turns on the *Heat* relay for a calculated amount of time. This amount of time is the "ON time". The ON time is calculated based on the requirements of the zone. If the zone requires more heating, the ON time is increased. If the zone requires less heating, the ON time is reduced.

In order to prevent short cycling of the heating relay, the thermostat ensures that the relay remains on or off for a minimum amount of time.

An AUTO CYC setting is available for the heating cycle. This setting allows the thermostat to determine the best number of cycles per hour that balances both temperature swings and equipment cycles.

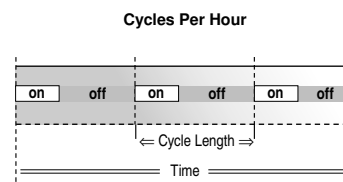

AUXILIARY SENSOR (508 Only)

The thermostat has a single built-in sensor to measure air temperature at the thermostat. In addition to the built-in sensor, the thermostat has terminals to connect one auxiliary sensor. This sensor can be either an indoor sensor, a slab sensor, or an outdoor sensor.

Indoor Sensor

An indoor sensor is used to measure the air temperature in the zone that the thermostat is controlling. The temperature being read by the indoor sensor is used in the calculations of the ON time for the relay in the thermostat. This setting is made through the *Adjust* menu of the thermostat. If the built-in sensor is set to ON and the auxiliary sensor is set to Indoor, the temperatures of the sensors are averaged and used to calculate the ON time of the relay.

Slab Sensor

A slab sensor is used to measure the slab temperature in the zone that the thermostat is controlling. The temperature being read by the slab sensor is used in the calculations of the ON time for the *Heat* relay and allows the thermostat to operate the slab between the slab minimum and slab maximum settings.

Outdoor Sensor

An outdoor sensor can be connected to the thermostat. The temperature measured by an outdoor sensor does not affect the ON time of the relay and is only used for display purposes.

ACCESS LEVELS (508 Only)

The 508 thermostat has two access levels. These access levels restrict the number of items available in the menus of the thermostat. The two access levels are User and Installer. This selection is made using the DIP switch located on the circuit board inside the thermostat.

Installer access level - allows the installer to adjust all of the settings in the thermostat including those required to match the thermostat to the mechanical system and the devices used.

User access level - allows the end user to adjust the temperatures used by the thermostat.

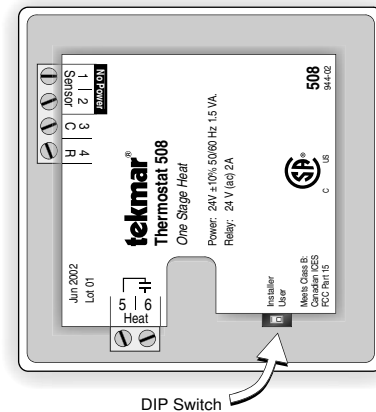

DIP Switch

Sequence of Operation

AIR SENSOR(S) ONLY OPERATION

When operating with only an air sensor, the ON time for the *Heat* relay is calculated to satisfy the requirements of the air sensor.

SLAB SENSOR ONLY OPERATION (508 Only)

When operating with only a slab sensor, the ON time for the *Heat* relay is calculated to satisfy the requirements of the slab sensor. The thermostat operates to maintain the slab at the minimum slab temperature setting.

Note: Operating with only a slab sensor can lead to either overheating or underheating of the space.

AIR AND SLAB SENSOR OPERATION (508 Only)

When operating with both air and slab sensors, the thermostat calculates an ON time for the *Heat* relay to satisfy the slab sensor's requirements and an ON time to satisfy the air sensor's requirements. The *Heat* relay operates for the longer of these two ON times.

During light heating loads, overheating can occur due to the minimum slab temperature requirements.

During heavy heating loads, the maximum slab temperature setting limits the ON time of the *Heat* relay. In this situation, underheating can occur.

MODE

Heat In the heat mode, the *Heat* relay is operated to satisfy the temperature requirement of the zone.

Off In the OFF mode, the *Heat* relay is not operated.

Note: If an air or slab sensor is active in the OFF mode, a freeze protection is enabled that allows the Heat relay to be operated to keep the zone above 35°F (2°C).

Installation

STEP ONE GETTING READY

Check the contents of this package. If any of the contents are missing or damaged, please contact your wholesaler or tekmar sales representative for assistance.

Type 507 Includes: One Thermostat 507, Data Brochure D 507, User Brochure U 507

Type 508 Includes: One Thermostat 508, Data Brochure D 507, User Brochure U 507

Type 509 Includes: One Thermostat 508, One Slab Sensor 079, Data Brochure D 507, User Brochure U 507, Data Brochure D 079

STEP TWO REMOVING THE FRONT COVER

Place a screwdriver or similar object into the small slot located in the top of the thermostat. Push the screwdriver against the plastic tab and pull the top of the front cover so that it pivots around the bottom edge of the base.

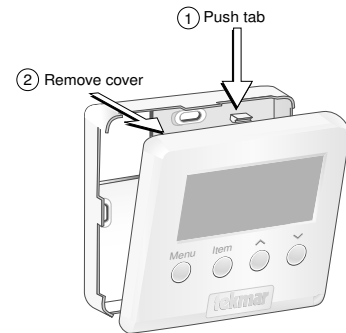

STEP THREE MOUNTING THE BASE

The thermostat should be installed on an interior wall of the desired zone approximately 5' (1.5 m) above the floor. Do not mount the thermostat in a location that may be affected by localized heat sources or cold drafts. It may be necessary to install a draft barrier behind the thermostat to prevent air from blowing through the wiring hole and affecting the thermostat's built-in sensor.

Mount the base directly to the wall using two #6 1" screws. The screws are inserted through the mounting holes and must be securely fastened to the wall. If possible, at least one of the screws should enter a wall stud or similar surface. If the thermostat is to be mounted to a 2" x 4" electrical box, order an Adaptor Plate 007. This plate mounts to the electrical box and the thermostat mounts to the plate. Ensure that the electrical box does not provide cold air to the thermostat.

Note: If the 508 is to be used for remote sensing (i.e. The built-in air sensor is disabled and an indoor sensor is being used.) Mount the thermostat in the desired location in an appropriate manner.

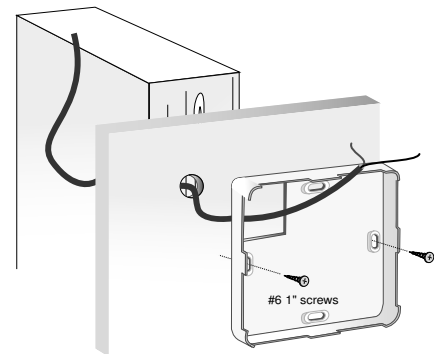

STEP FOUR ROUGH IN WIRING

- 18 AWG or similar wire is recommended for all 24 V (ac) wiring.
- All wires are to be stripped to ¼" (6 mm) to ensure proper connection to the control.
- Run wires from the 24 V (ac) power to the thermostat. Use a clean power source to ensure proper operation.
- If an auxiliary sensor is used, install the sensor according to the appropriate Data Brochure and run two wires from the sensor to the thermostat.
- Run wires from the heating device to the thermostat.

STEP FIVE WIRING THE THERMOSTAT

(Refer to the examples on the following page.)

24 V (ac) Power

Connect the 24 V (ac) power to the R and C terminals of the thermostat. This connection provides power to the microprocessor and display of the thermostat.

Auxiliary Sensor (508 Only)

Either an indoor, slab, or outdoor sensor may be connected to the auxiliary sensor input. Connect the two wires from the auxiliary sensor to the Sensor terminals.

Heat Relay

The *Heat* terminals are an isolated output. There is no power available on these terminals from the thermostat. These terminals are to be used as a switch for a 24 V (ac) circuit. This circuit can operate a low current 24 V (ac) device directly or an external relay to enable a line voltage or high current device.

STEP SIX ——— INSTALLING THE FRONT COVER ———

Align the hinges on the bottom of the front cover with the bottom of the thermostat mounting base. Pivot the front cover around the bottom hinges and push the top against the mounting base until it snaps firmly in place.

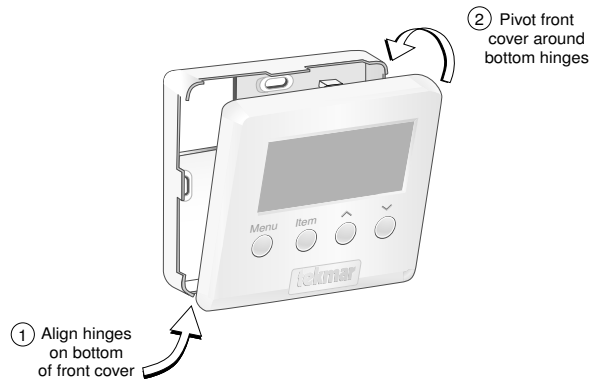

Wiring Examples

WIRING 24 V (AC) POWER (507)

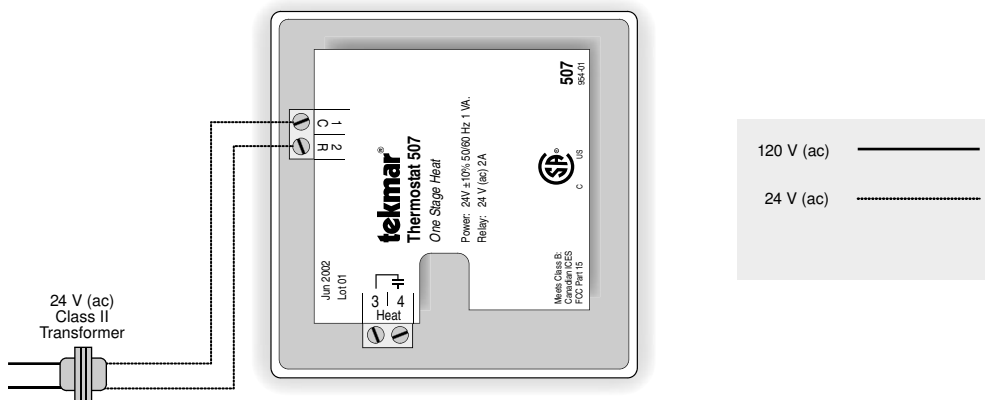

WIRING 24 V (AC) POWER AND AUXILIARY SENSOR (508)

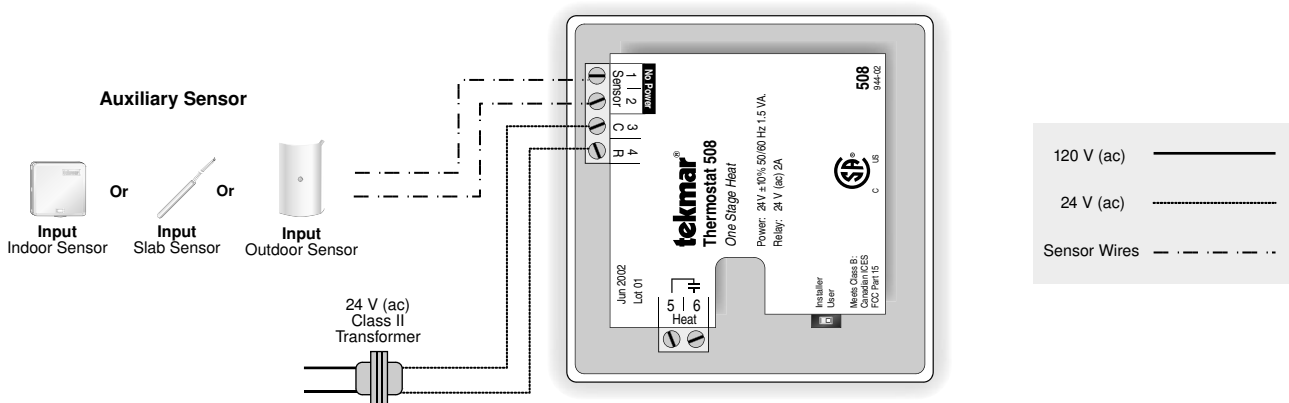

Wiring to 24 V (ac) Zone Valve

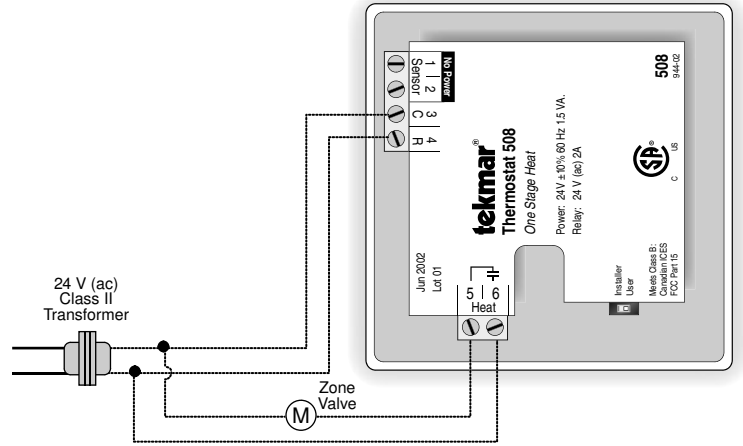

Wiring to Unpowered 24 V (ac) Relay

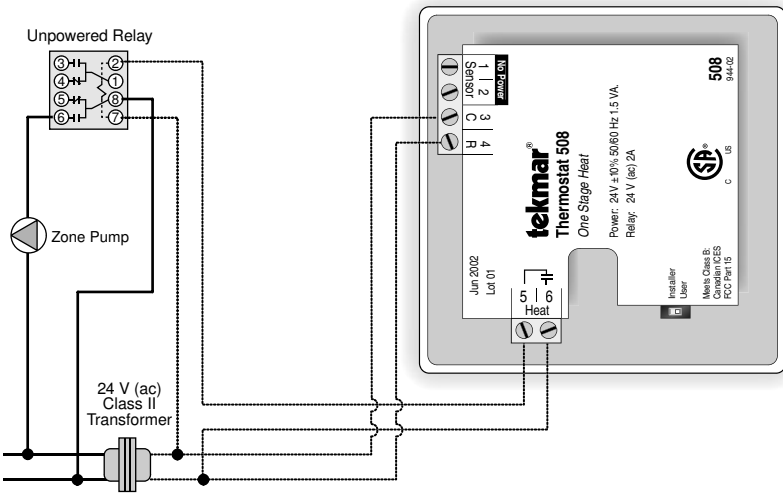

Wiring to Powered 24 V (ac) Relay

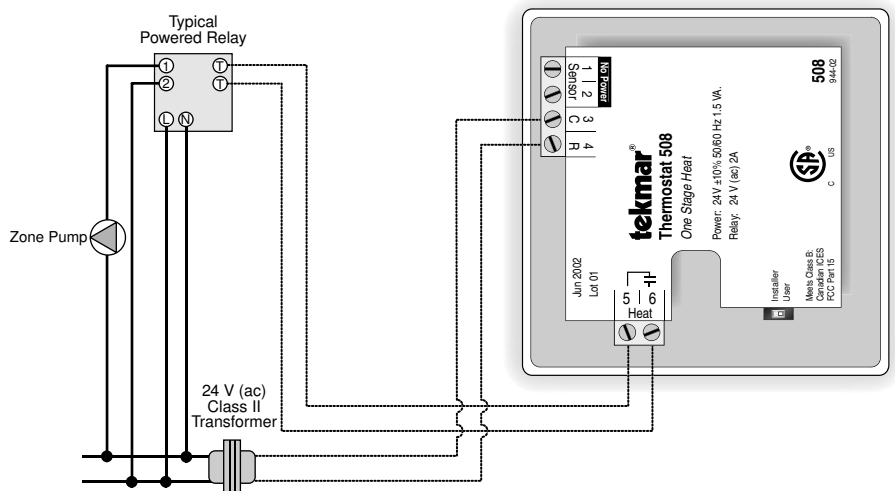

View Menu

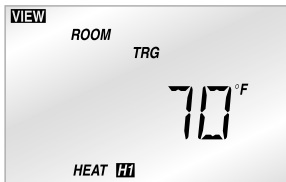

ROOM TARGET

The current desired air temperature for the space. This item is only available in the Installer access level.

(Must have an active air sensor.)



OUTDOOR (508 Only)

The current temperature at the outdoor sensor.

(SENS must be set to OUT.)



ROOM

The current air temperature for the space.

(Must have at least one active air sensor. This is the average of all active air sensors.)



SLAB (508 Only)

The current slab temperature.

(Must have an active slab sensor.)

The MIN segment is displayed when running at Slab Minimum.

Adjust Menu

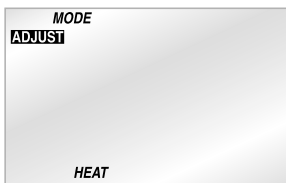

MODE

Current mode of operation of the thermostat.

OFF, HEAT

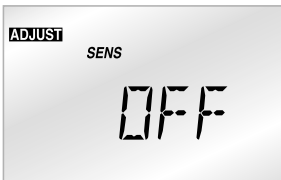

SENSOR (508 Only)

Selects the type of auxiliary sensor present. This item is only available in the Installer access level.

OFF, Indr, SLAB, OUT

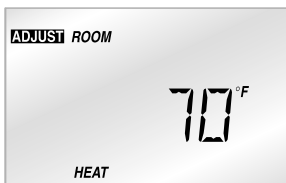

ROOM HEAT

Desired temperature for heating.
(Must have an active air sensor and be set to HEAT.)

35 to 100°F (1.5 to 38.0°C)

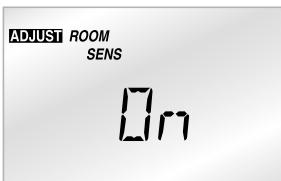

ROOM Sensor (508 Only)

Selects whether the built-in sensor is functional or not. This item is only available in the Installer access level.

OFF, On



SLAB MINIMUM (508 Only)

Minimum slab temperature.
(Must have an active slab sensor.)

OFF, 34 to 122°F (OFF, 1.0 to 50.0°C)

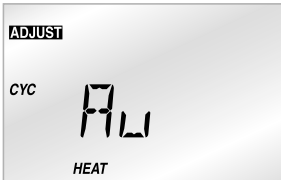

HEATING CYCLE

Determines the number of cycles per hour for the heating equipment. This item is only available in the Installer access level.

Au, 2 to 12



SLAB MAXIMUM (508 Only)

Maximum slab temperature. This item is only available in the Installer access level.

(Must have an active slab sensor.)

34 to 122°F, OFF (1.0 to 50.0°C, OFF)



UNITS

The units of temperature used to display the items.

°F, °C

Error Messages



E01 The thermostat was unable to read a piece of information stored in its memory. The thermostat was required to load the factory settings. The thermostat will stop operation until all settings are checked. To clear this error, select the Installer access level and check all of the settings in the *Adjust* menu.



Room Open The thermostat's internal air sensor is open circuit. This cannot be repaired in the field. Either turn off the internal sensor and use an auxiliary sensor set to INDR or replace the thermostat. After the fault is corrected, press any button to clear the error message.



E02 There are no active sensors selected on the thermostat. Either the internal sensor must be turned on or the auxiliary sensor must be set to either INDR or SLAB. After the fault is corrected, press any button to clear the error message.

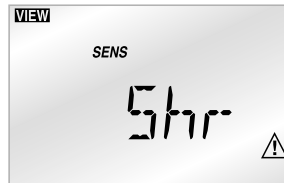

Sensor Short The auxiliary sensor is short circuit. Locate and repair the problem as described in the appropriate sensor brochure. After the fault is corrected, press any button to clear the error message.



Room Short The thermostat's internal air sensor is short circuit. This cannot be repaired in the field. The thermostat should be replaced or returned for repair.

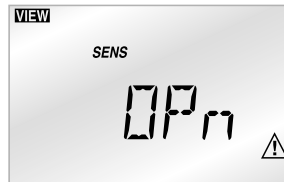

Sensor Open The auxiliary sensor is open circuit. Locate and repair the problem as described in the appropriate sensor brochure. After the fault is corrected, press any button to clear the error message.

Technical Data

Thermostat 507 One Stage Heat

Literature	— D 507, U 507
Control	— Microprocessor PI control; This is not a safety (limit) control .
Packaged weight	— 0.46 lb. (210 g), Enclosure J, white PVC plastic
Dimensions	— 2-7/8" H x 2-7/8" W x 13/16" D (73 x 73 x 21 mm)
Approvals	— CSA C US, meets ICES & FCC regulations for EMI/RFI.
Ambient conditions	— Indoor use only, -22 to 131°F (-30 to 55°C), < 90% RH non-condensing.
Power supply	— 24 V ±10% 50/60 Hz 1 VA
Relay	— 24 V (ac) 2 A

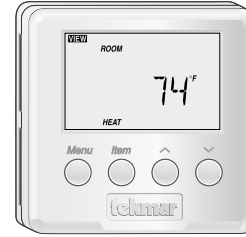

Thermostat 509 (508 / 079) One Stage Heat

Literature	— D 507, U 507, D 079
Control	— Microprocessor PI control; This is not a safety (limit) control .
Packaged weight	— 0.54 lb. (245 g), Enclosure J, white PVC plastic
Dimensions	— 2-7/8" H x 2-7/8" W x 13/16" D (73 x 73 x 21 mm)
Approvals	— CSA C US, meets ICES & FCC regulations for EMI/RFI.
Ambient conditions	— Indoor use only, -22 to 131°F (-30 to 55°C), < 90% RH non-condensing.
Power supply	— 24 V ±10% 50/60 Hz 1.5 VA
Relay	— 24 V (ac) 2 A
Sensors	— NTC thermistor, 10 kΩ @ 77°F (25°C ±0.2°C) β=3892
Included	— Slab Sensor 079
Optional	— tekmar type #: 070, 071, 072, 073, 076, 077, 078, 079.

Thermostat 508 One Stage Heat

Literature	— D 507, U 507
Control	— Microprocessor PI control; This is not a safety (limit) control .
Packaged weight	— 0.46 lb. (210 g), Enclosure J, white PVC plastic
Dimensions	— 2-7/8" H x 2-7/8" W x 13/16" D (73 x 73 x 21 mm)
Approvals	— CSA C US, meets ICES & FCC regulations for EMI/RFI.
Ambient conditions	— Indoor use only, -22 to 131°F (-30 to 55°C), < 90% RH non-condensing.
Power supply	— 24 V ±10% 50/60 Hz 1.5 VA
Relay	— 24 V (ac) 2 A
Sensors	— NTC thermistor, 10 kΩ @ 77°F (25°C ±0.2°C) β=3892
Included	— None
Optional	— tekmar type #: 070, 071, 072, 073, 076, 077, 078, 079.

The installer must ensure that this control and its wiring are isolated and/or shielded from strong sources of electromagnetic noise. Conversely, this Class B digital apparatus complies with Part 15 of the FCC Rules and meets all requirements of the Canadian Interference-Causing Equipment Regulations. However, if this control does cause harmful interference to radio or television reception, which is determined by turning the control off and on, the user is encouraged to try to correct the interference by re-orientating or relocating the receiving antenna, relocating the receiver with respect to this control, and/or connecting the control to a different circuit from that to which the receiver is connected.

Cet appareil numérique de la classe B respecte toutes les exigences du Règlement sur le matériel brouilleur du Canada.

Caution The nonmetallic enclosure does not provide grounding between conduit connections. Use grounding type bushings and jumper wires.

Attention Un boîtier non métallique n'assure pas la continuité électrique des conduits. Utiliser des manchons ou des fils de accord spécialement conçus pour la mise à la terre.

Limited Warranty and Product Return Procedure

Limited Warranty *The liability of tekmar under this warranty is limited. The Purchaser, by taking receipt of any tekmar product ("Product"), acknowledges the terms of the Limited Warranty in effect at the time of such Product sale and acknowledges that it has read and understands same.*

The tekmar Limited Warranty to the Purchaser on the Products sold hereunder is a manufacturer's pass-through warranty which the Purchaser is authorized to pass through to its customers. Under the Limited Warranty, each tekmar Product is warranted against defects in workmanship and materials if the Product is installed and used in compliance with tekmar's instructions, ordinary wear and tear excepted. The pass-through warranty period is for a period of twenty-four (24) months from the production date if the Product is not installed during that period, or twelve (12) months from the documented date of installation if installed within twenty-four (24) months from the production date.

The liability of tekmar under the Limited Warranty shall be limited to, at tekmar's sole discretion: the cost of parts and labor provided by tekmar to repair defects in materials and/or workmanship of the defective product; or to the exchange of the defective product for a warranty replacement product; or to the granting of credit limited to the original cost of the defective product, and such repair, exchange or credit shall be the sole remedy available from tekmar, and, without limiting the foregoing in any way, tekmar is not responsible, in contract, tort or strict product liability, for any other losses, costs, expenses, inconveniences, or damages, whether direct, indirect, special, secondary, incidental or consequential, arising from ownership or use of the product, or from defects in workmanship or materials, including any liability for fundamental breach of contract.

The pass-through Limited Warranty applies only to those defective Products returned to tekmar during the warranty period. This Limited Warranty does not cover the cost of the parts or labor to remove or transport the defective Product, or to reinstall the repaired or replacement Product, all such costs and expenses being subject to Purchaser's agreement and warranty with its customers.

Any representations or warranties about the Products made by Purchaser to its cus-

tomers which are different from or in excess of the tekmar Limited Warranty are the Purchaser's sole responsibility and obligation. Purchaser shall indemnify and hold tekmar harmless from and against any and all claims, liabilities and damages of any kind or nature which arise out of or are related to any such representations or warranties by Purchaser to its customers.

The pass-through Limited Warranty does not apply if the returned Product has been damaged by negligence by persons other than tekmar, accident, fire, Act of God, abuse or misuse; or has been damaged by modifications, alterations or attachments made subsequent to purchase which have not been authorized by tekmar; or if the Product was not installed in compliance with tekmar's instructions and/or the local codes and ordinances; or if due to defective installation of the Product; or if the Product was not used in compliance with tekmar's instructions.

THIS WARRANTY IS IN LIEU OF ALL OTHER WARRANTIES, EXPRESS OR IMPLIED, WHICH THE GOVERNING LAW ALLOWS PARTIES TO CONTRACTUALLY EXCLUDE, INCLUDING, WITHOUT LIMITATION, IMPLIED WARRANTIES OF MERCHANTABILITY AND FITNESS FOR A PARTICULAR PURPOSE, DURABILITY OR DESCRIPTION OF THE PRODUCT, ITS NON-INFRINGEMENT OF ANY RELEVANT PATENTS OR TRADEMARKS, AND ITS COMPLIANCE WITH OR NON-VIOLATION OF ANY APPLICABLE ENVIRONMENTAL, HEALTH OR SAFETY LEGISLATION; THE TERM OF ANY OTHER WARRANTY NOT HEREBY CONTRACTUALLY EXCLUDED IS LIMITED SUCH THAT IT SHALL NOT EXTEND BEYOND TWENTY-FOUR (24) MONTHS FROM THE PRODUCTION DATE, TO THE EXTENT THAT SUCH LIMITATION IS ALLOWED BY THE GOVERNING LAW.

Product Warranty Return Procedure All Products that are believed to have defects in workmanship or materials must be returned, together with a written description of the defect, to the tekmar Representative assigned to the territory in which such Product is located. If tekmar receives an inquiry from someone other than a tekmar Representative, including an inquiry from Purchaser (if not a tekmar Representative) or Purchaser's customers, regarding a potential warranty claim, tekmar's sole obligation shall be to provide the address and other contact information regarding the appropriate Representative.



tekmar Control Systems Ltd., Canada
tekmar Control Systems, Inc., U.S.A.
Head Office: 5100 Silver Star Road
Vernon, B.C. Canada V1B 3K4
(250) 545-7749 Fax. (250) 545-0650
Web Site: www.tekmarcontrols.com

