



INDUSTRIES LIMITED

MODEL MF200 'PRESSURE PAL' MINI SYSTEM FEEDER

The 'PRESSURE PAL' is ideal for feeding and pressurizing closed hydronic systems that do not require cold static fill pressures higher than 125 kPa (18 psig). It is compatible with both water and glycol/water solutions. Perfect for small boiler/chiller systems, snow/ice melt circuits, outside air heating/cooling glycol coils, solar heating systems.



FEATURES and BENEFITS

- 22.7 liter (6.0 US gallon) tank for storage and mixing
- Power supply plugs into any standard 115 VAC outlet
- Diaphragm pump can run dry without damage
- No direct connection to potable water supply eliminates need for backflow prevention
- Make-up fluid stored in the feeder tank can be pre-treated
- Diverter valve allows easy purging of air on initial start-up, and manual agitation of solution
- Prevents major floods - in the event of system rupture, only the contents of the tank will be pumped into the system
- Provides leak detection - dropping fluid level provides immediate notice that the system has developed a leak
- Fluid drained for service can easily be put back into the system
- Fluid level switch shuts the pump off if the storage tank level gets too low
- Auxiliary dry contact included for remote low pressure alarm (alarm optional or by others)

Represented By:



MF200 HYDRONIC SYSTEM FEEDER TECHNICAL INFORMATION

WEIGHT - 3.2 kg, 7 lbs.

ELECTRICAL

Fused Power supply adapter
115/60/1 to 24 VDC
Rated 50 watts AC
LED Power Light

PUMP PERFORMANCE

0.04 l/s (0.7 gpm) @ free flow
Self-priming up to 1.2 m (4 feet)

SPECIFICATION

Hydronic system feeder shall be AXIOM INDUSTRIES LTD. Model MF200. System shall include 25 litre (6.6 U.S. gallon) storage/mixing tank with molded-in level gauge, 125 mm (5") fill/access opening and cover; pump suction hose with inlet strainer and check valve; pressure pump with fuse protection; low fluid level pump cut-out float switch; manual diverter valve for purging air and agitating contents of storage tank; pressure switch with snubber and two sets of SPST dry contacts, each individually adjustable from 55 kPa (8 psig) to 125 kPa (18 psig) cut-out pressure; factory cut-out pressure set to 97 kPa (14psig); and liquid filled pressure gauge. Unit to be c/w fused power supply adapter with LED power indicator light, 115/60/1 to 24 VDC 50 watts AC, supplied loose for field installation.

Feeder shall be compatible with glycol solutions of up to 50% concentration. Pump shall be capable of running dry without damage. The second set of contacts in the pressure switch shall be wired to a terminal strip for use as low pressure alarm contacts for remote alarm circuit supplied by others. Unit shall be completely assembled.

ACCESSORIES

- MF200-1430** – Tank Mounting Shelf
- RIA10-1-SAA** – Low Pressure Alarm Panel c/w Remote Monitoring Dry Contacts and Selectable Audible Alarm

LIMITED WARRANTY

The MF200 is warranted against defects in materials and workmanship for one year.

Project _____ Location _____

Consultant _____ Contractor _____

Unit Tag _____ Sales Agent _____

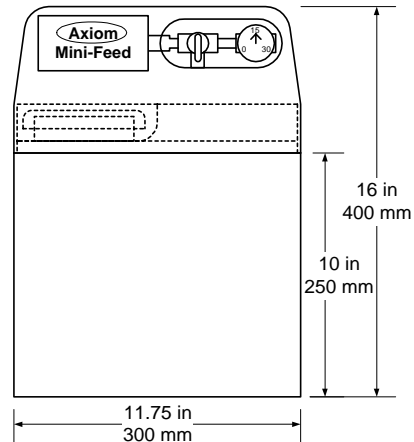

Depth - 11.75 in 300 mm
 Clearances - Sides and Top - 12 in 305 mm
 Weight When Full 60 lbs/27 kg.
 Discharge 1/4" FPT