



# ***Twin-Flo III* HEATER FLOOR KIT**

## **INSTALLATION INSTRUCTIONS**

Attention: Read these instructions carefully before attempting to install, operate, or service the Beacon-Morris Twin-Flo III heaters! Retain these instructions for future reference.

Inspect the shipment immediately when received to determine if any damage has occurred during shipment.

Prior to installation, check for any visible damage.

### **GENERAL DESCRIPTION**

The Twin-Flo III Floor Kits have been designed to accommodate a Beacon-Morris Twin-Flo III Model K42, K84 or K120 heater to deliver a comfortable stream of warmed air at floor level by a unit mounted beneath the floor.

Kits consist of a cabinet chassis, heater mounting plate, discharge duct, deflector, grille and necessary hardware for securing chassis, heater and mounting plate.

The main cabinet chassis will fit between 16" center floor joists either perpendicular or parallel to the joists.

***NOTE: Models K84 & K120 Floor Kits main cabinet can only be located parallel to floor joists.***

Installation Instructions should be read thoroughly *IN CONJUNCTION WITH INSTALLATION INSTRUCTIONS AND WIRING DIAGRAM SUPPLIED WITH TWIN-FLO III HEATER UNITS*, prior to starting installation.

**WARNING: DISCONNECT POWER BEFORE SERVICING UNIT,  
POTENTIAL ELECTRICAL SHOCK HAZARD.**

### **FLOOR KIT LOCATION**

1. Select a location in the floor where unit is to be located. Cut a rectangular opening 6" x 13-7/8" for an FK-42 unit or 6" x 21-7/8" for an FK-84 or FK120 unit. (See Fig. A, B, or C for unit arrangement). Opening for FK-42 unit may be located either parallel to joists or perpendicular to joists. Opening for FK-84 or FK120 can only be located parallel to joists. On parallel mounted units 13-7/8" length or 21-7/8" length opening must be cut flush with joist. On perpendicular mounted units 13-7/8" length opening must be centrally located between the joists.

2. On parallel mounted units, locate main cabinet central to opening with small end flush with opening and against joists. Top of cabinet to be flush with top of joists only. Fasten with wood screws to joists on each end. (See Fig. D)
3. On perpendicular mounted units (FK-42 only) locate small end of main cabinet flush with far end of opening and flush with top of joists. Secure cabinet sides to joists with wood screws. (See Fig E)

### TWIN-FLO III HEATER

1. Temporarily place and locate the Twin-Flo III on studs provided on bottom plate. This procedure locates rectangular opening for piping. Soldering elbows on inlet and outlet of element must not extend beyond edge of bottom plate. Remove unit and proceed with piping as described in Beacon-Morris Twin-Flo III Heater Instalaltion Instructions. (See Fig G)
2. Remove (3) screws form electric connector box and remove cover.
3. Secure unit to bottom plate through the (4) resilient mounting feet, (2) are located beneath the electrical connector box. Torque nuts so that unit will not move or vibrate.
4. Loosen the (2) screws at the outlet end of the element cover.
5. Insert discharge duct into outlet end, side flanges to be inside element covers and top flanges to be outside element covers. Slide duct as far as it will go.
6. Tighten the (2) screws and replace electrical connector box cover and secure with (3) screws.
7. Locate neoprene gasket on electrical connector box cover approximately 5" from blower end.
8. Insert deflector into slots on intake end of blower housing. Deflector to be flush with side of electrical connector box and resting solidly on gasket.
9. Remove desired knockouts in electrical connector box and bottom panel.

### FINAL ASSEMBLY

1. Take the assembled heater and bottom panel and insert offset end of panel inside small end of main cabinet, swing opposite end upward until bottom panel is seated against bottom of cabinet. Studs in bottom of cabinet will protrude far enough below panel to enable securing with washer and wing nut.
2. Make final piping and electrical connections following the instructions outlined in the Beacon-Morris Twin-Flo III Heater Installation Instruction manual.
3. Slip grill assembly into floor. (See Fig. G)
4. See Fig H for replacement parts list.

Fig. A

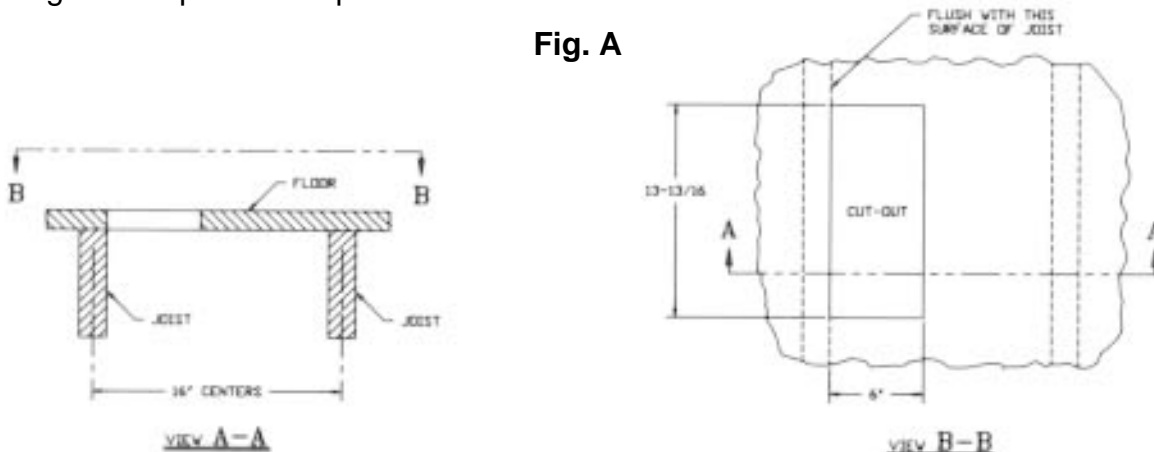

MODEL FK-42 FLOOR KIT  
CUT OUT ARRANGEMENT  
PARALLEL TO JOISTS

**Fig. B**

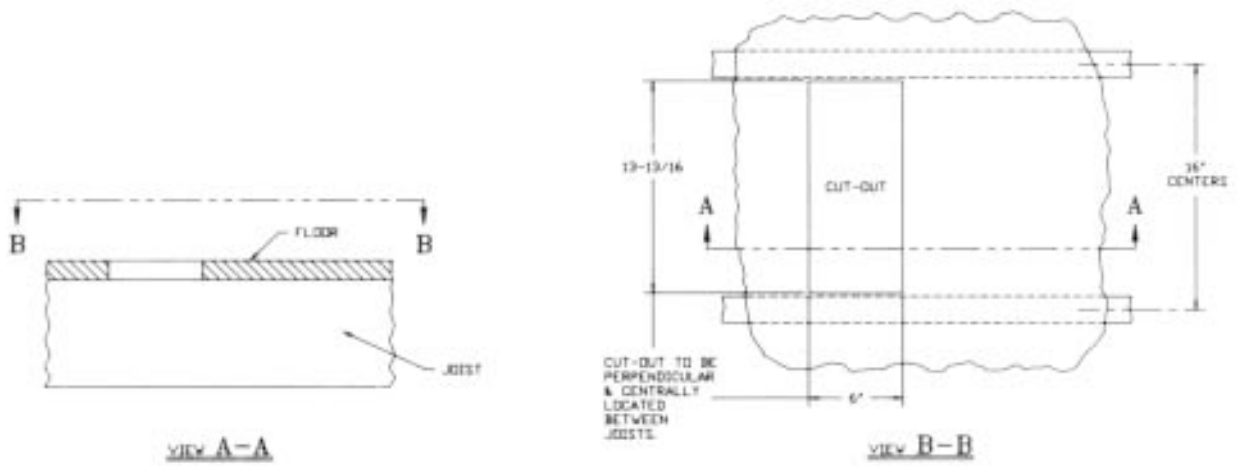

**MODEL FK-42 FLOOR KIT  
CUT-OUT ARRANGEMENT  
PERPENDICULAR TO JOISTS**

**Fig. C**

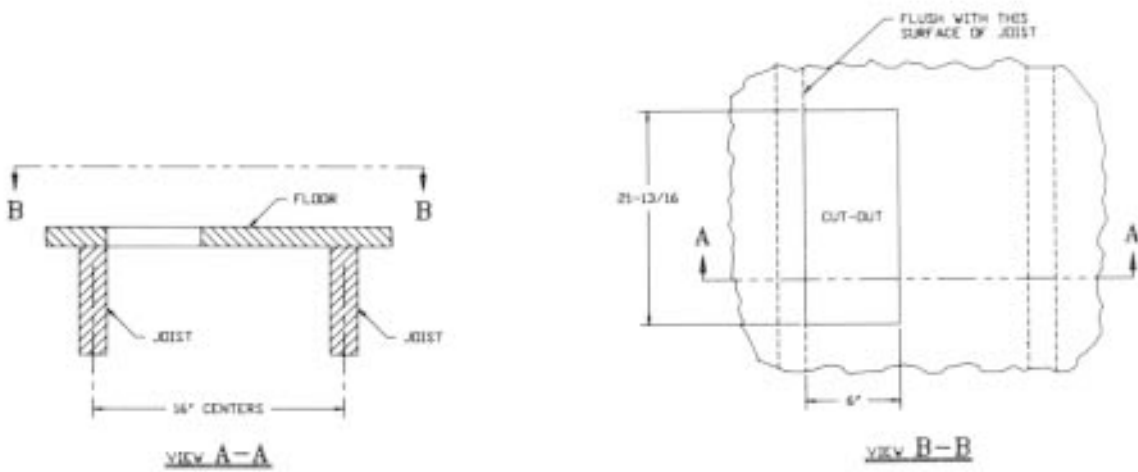

**MODEL FK-84 & FK120 FLOOR KIT  
CUT-OUT ARRANGEMENT  
PARALLEL TO JOISTS**

Fig. D

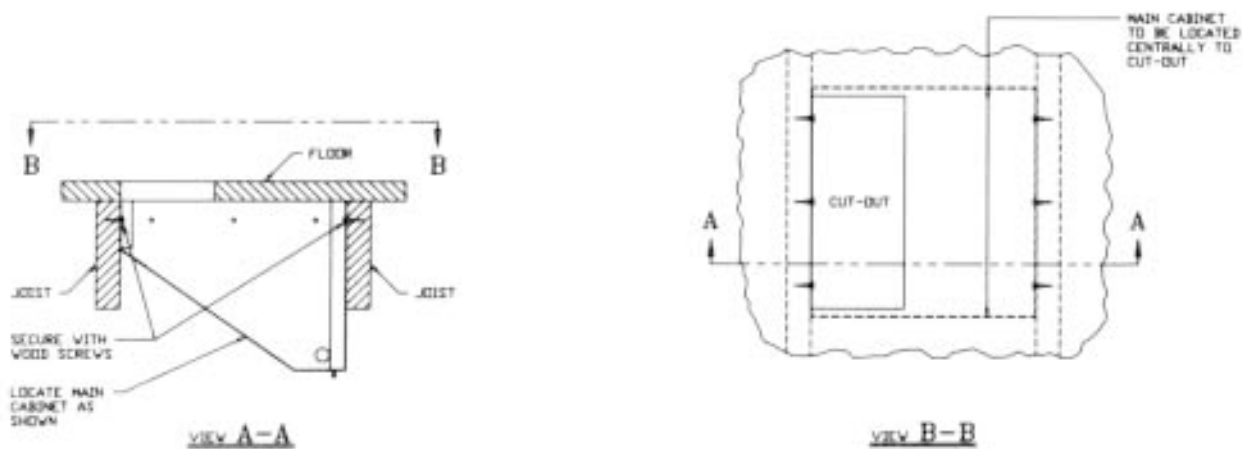

MODELS FK-42, FK-84 & FK-120 FLOOR KIT  
MAIN CABINET PARALLEL MOUNTING

Fig. E

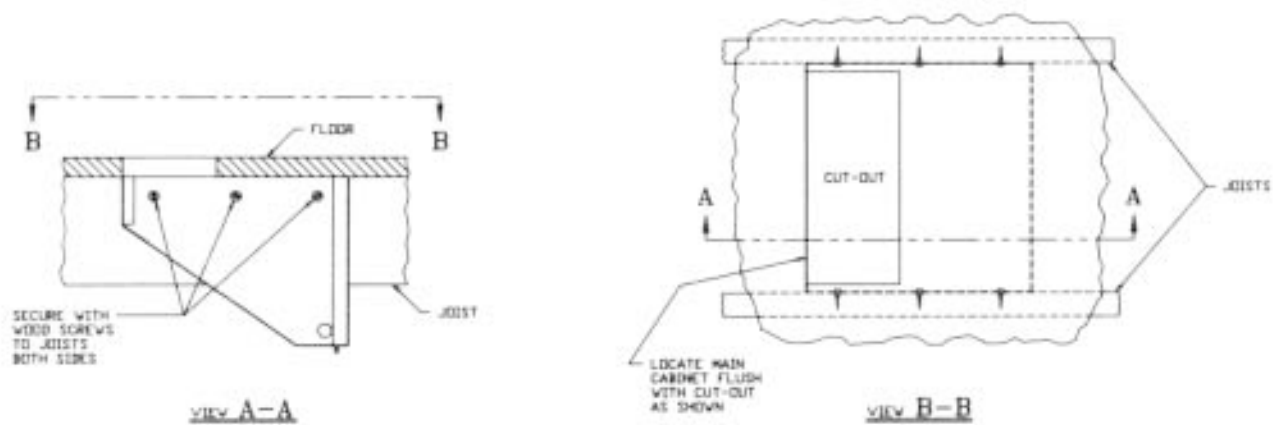

MODEL FK-42 FLOOR KIT (ONLY)  
MAIN CABINET PERPENDICULAR MOUNTING

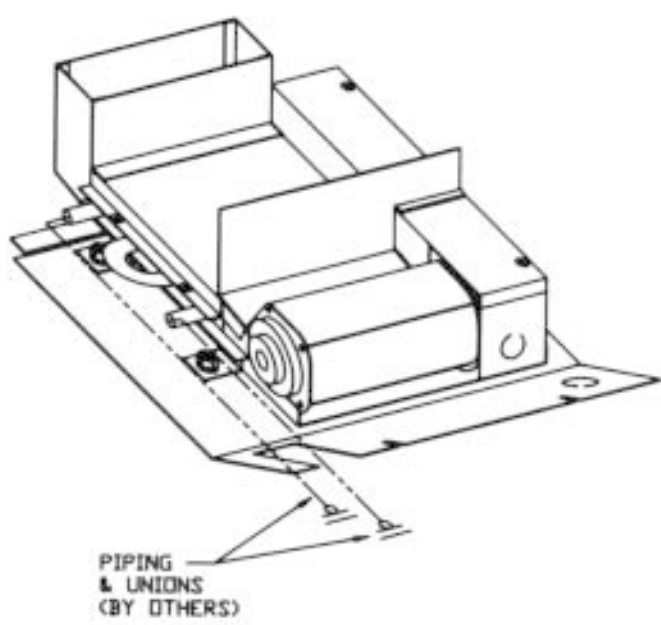
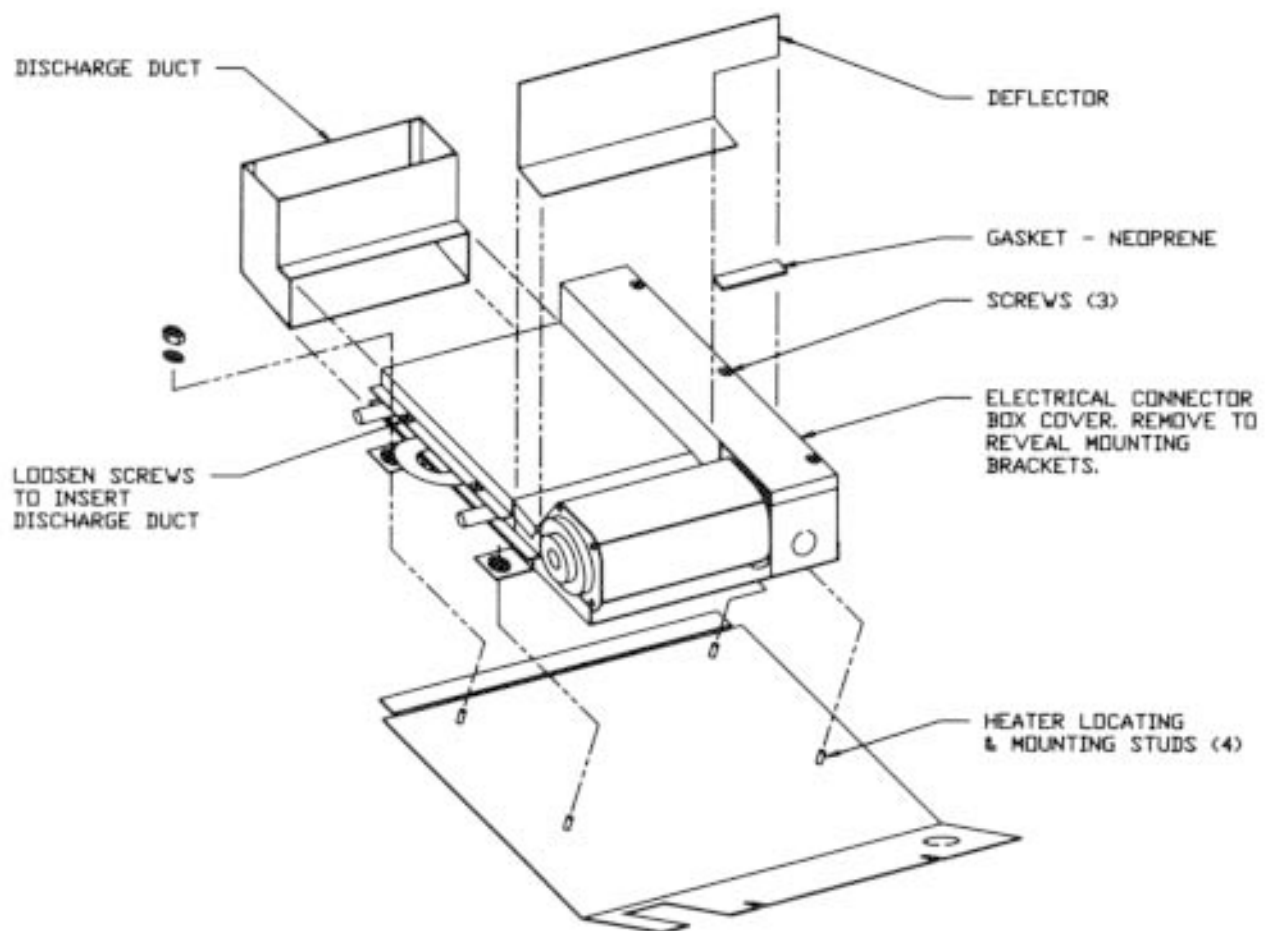

Fig. F

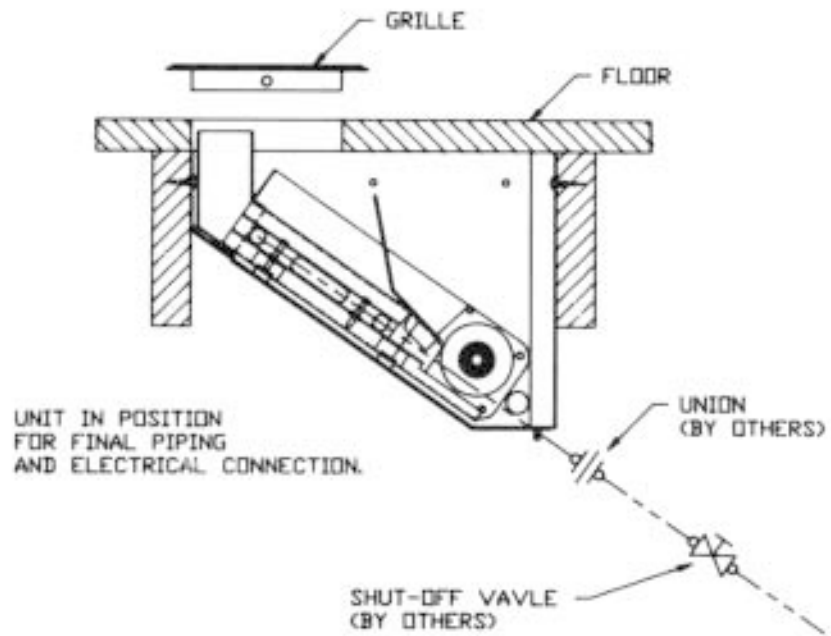
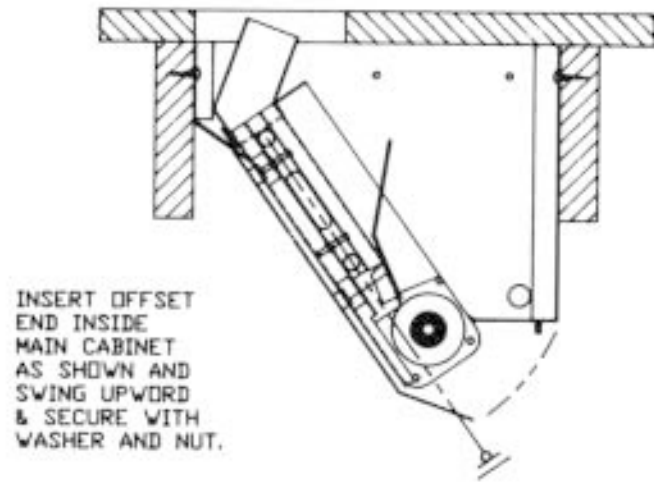
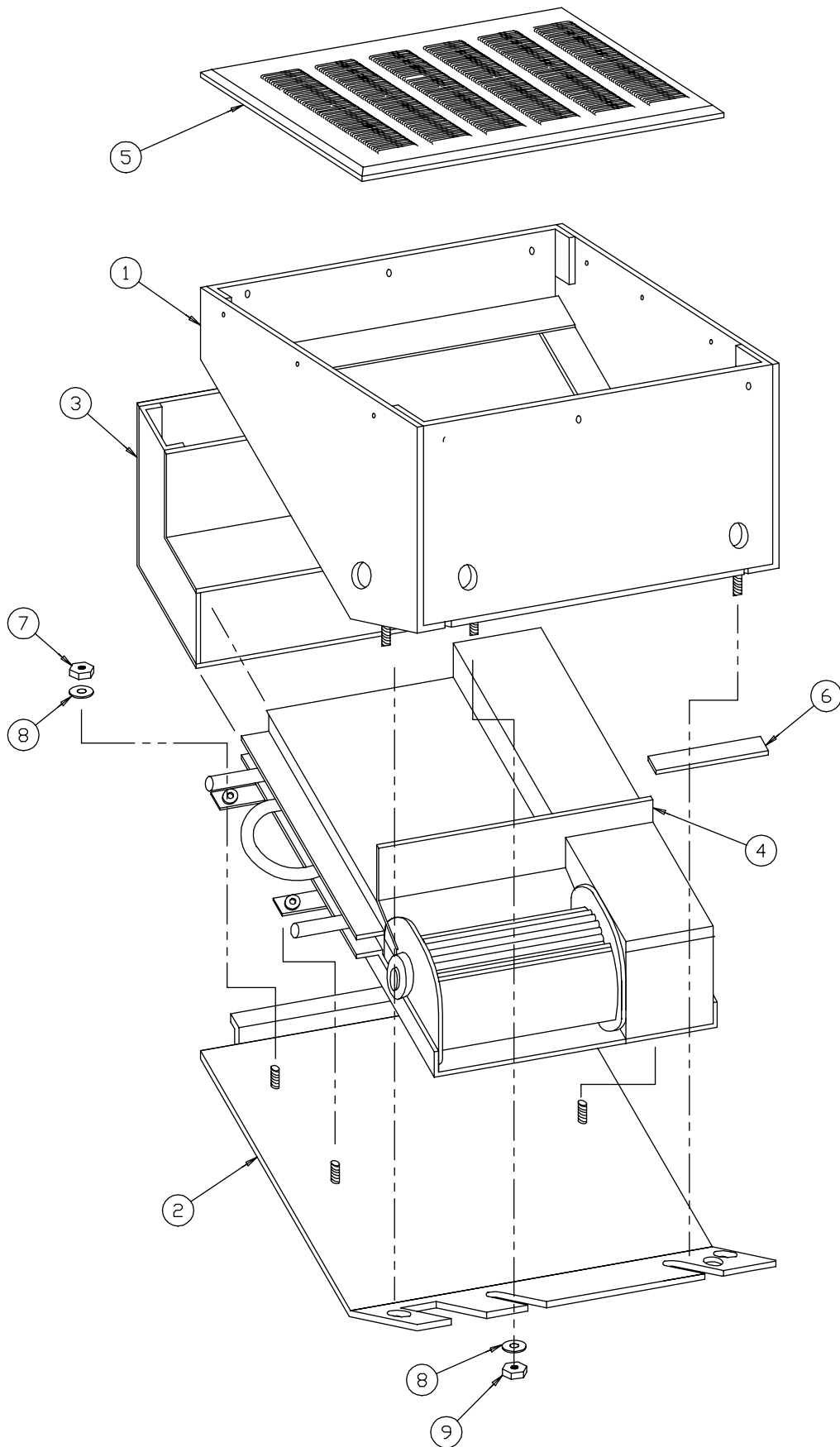

Fig G



**Fig. H**

## REPLACEMENT PARTS LIST

DET. NO.	DESCRIPTION	QTY	MODEL NO.		
			FK-42	FK-84	FK-120
1	MAIN CABINET	1	FK- 42/84-2423-1	FK- 42/84-2423-2	FK- 42/84-2423-2
2	BOTTOM PLATE	1	FK-42/84-2435-1	FK-42/84-2435-2	FK-42/84-2435-2
3	DISCHARGE DUCT	1	FK-42/84-2429-1	FK-42/84-2429-2	FK-42/84-2429-3
4	DEFLECTOR	1	FK-42/84-2434-1	FK-42/84-2434-2	FK-42/84-2434-2
5	GRILLE	1	FK-42/84-2437-1	FK-42/84-2437-2	FK-42/84-2437-2
6	GASKETING	1	RTC-4/16-0653	RTC-4/16-0653	RTC-4/16-0653
7	HEX NUT	4	DPB-2/16-0324-1	DPB-2/16-0324-1	DPB-2/16-0324-1
8	WASHER	6	DPB-2/16-0322-1	DPB-2/16-0322-1	DPB-2/16-0322-1
9	WING NUT	2	TFK-41/82-1660-10	TFK-41/82-1660-10	TFK-41/82-1660-10