

Twin-Flo III[®]

The First Name in Kickspace Heaters



bm
Beacon/Morris[®]

Twin-Flo III® The Space Saving Alternative to Hot Water Baseboard



Twin-Flo III heater kitchen island installation.



Twin-Flo III heater staircase installation.



Twin-Flo III heater kitchen cabinet installation.



Twin-Flo III heater bathroom cabinet installation.

Kickspace Models

Three sizes to meet a wide range of heating needs

Twin-Flo III® kickspace heaters are your ideal solution wherever space is limited:

■ Under Cabinets

■ In Kitchens, Baths, and Foyers

■ Under Stair Risers and Windows



Model K42



Model K84

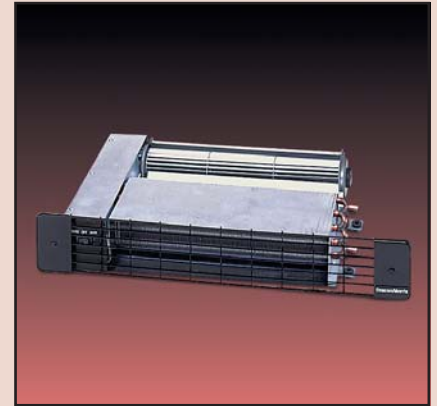

Model K120

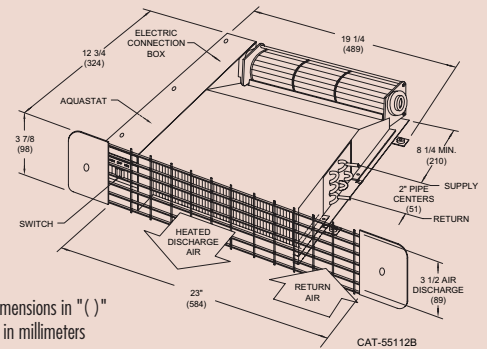
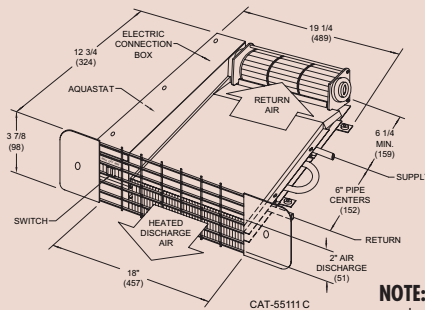
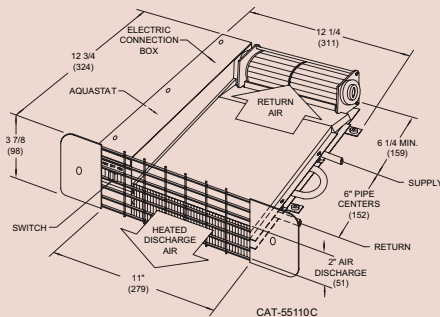

NOTE: Dimensions in " () " are shown in millimeters

Heating Capacity (BTU/Hr.*) for All Twin-Flo III Models

Entering Water Temperature (°F)	WATER FLOW RATE (GALLONS PER MINUTE)								
	1 Gal.			2 Gal.			3 Gal.		
	Model 42	Model 84	Model 120	Model 42	Model 84	Model 120	Model 42	Model 84	Model 120
**110	1480	3370	8425	1520	3440	8535	1560	3515	8730
**120	1800	4055	8875	1840	4145	8995	1875	4230	9205
**130	2175	4770	9330	2220	4875	9455	2260	4980	9680
140	2590	5540	9780	2640	5670	9915	2690	5795	10150
150	3050	6300	10230	3120	6440	10375	3190	6585	10625
160	3510	7000	10685	3590	7155	10835	3670	7310	11100
170	3895	7730	11135	3980	7900	11295	4065	8070	11570
180	4278	8460	11585	4375	8650	11755	4470	8840	12045
190	4660	9180	12035	4770	9390	12215	4875	9600	12520
200	5015	9910	12490	5127	10135	12675	5240	10360	12990
Friction Loss (head)	.17 ft.	.22 ft.	.43 ft.	.8 ft.	.95 ft.	1.45 ft.	1.2 ft.	1.5 ft.	2.97 ft.

*Based on 65°F entering air temperature with fan at high speed including the heating effect factor. Ratings reduced by 15% at low speed.

**Blower operates at water temperature above 140°F with standard self-contained aquastat. Optional low temperature aquastat available for low temperature applications.

Supply and return connections are 1/2" nominal. Units are not recommended for use with steam.

Installation Kits

Provide convenient, flexible installation options



Beacon/Morris offers kits for installing Twin-Flo^{III} units in locations other than the kickspace under a cabinet. Each kit comes with all the hardware needed to install the kickspace heater.

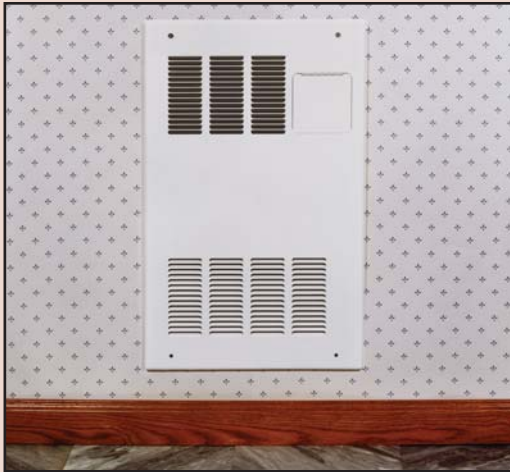

Recessed models finished in Cameo White with rounded edges.

Recessed • W42 • W84 • W120

Twin-Flo^{III} Recessed kits fit into wall recesses so they're ideal for narrow hallways, mud rooms, laundry areas, and other tight locations. The smaller Model W42 fits in between standard 16" center studs.

- Galvanized steel inner cabinet
- Cameo White baked enamel finish
- Color coordinated screw covers and rounded edges for neat appearance

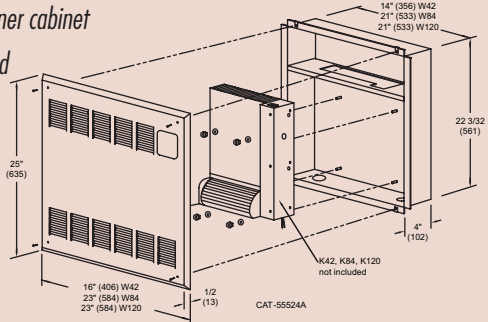

Surface models finished in Cameo White with sloped top and rounded edges.

Surface • F42 • F84 • F120

Twin-Flo^{III} Surface kits install quickly and easily — directly to a wall surface. They add warmth to cold hallways, bathrooms, kitchens, laundry rooms, family rooms, work shops, and additions.

- Galvanized steel inner cabinet
- Cameo White baked enamel finish
- New sloped top and rounded edges for neat appearance

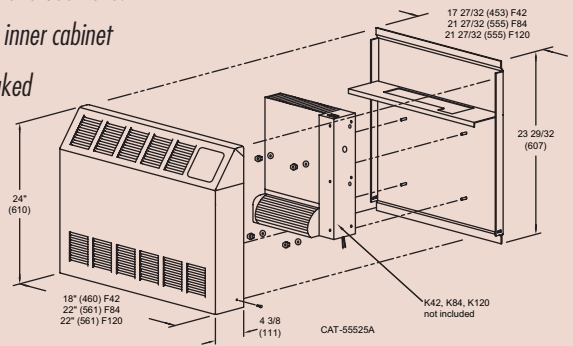

In the Floor Kit features "heel proof" grille in cameo white.

Floor • FK42 • FK84 • FK120

Where glassed-in walls or sliders leave little room for heating units, Twin-Flo^{III} Floor kits install easily between standard floor joists. The grille provides a choice of forward or rear directional air flow and easy accessibility for routine maintenance.

- Heavy 16 gauge steel grill can be rotated for front or rear discharge
- Protective screen under grill
- Cameo white baked enamel finish

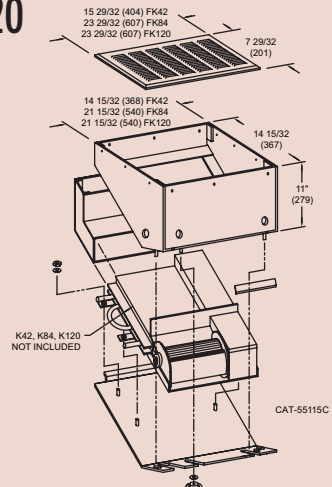

NOTE: Dimensions in "()" are shown in millimeters

Features and Benefits

The first name in kickspace heaters

Why Kickspace Heaters?

Kickspace heaters are the space-saving alternative to hot water baseboard. Designed to fit inconspicuously under a cabinet, in the floor, on or in the wall, kickspace heaters are ideal for hard to heat areas such as foyers, kitchens, and bathrooms.

Hot water from the home's boiler is circulated through the kickspace unit and the fan gently blows heated air into the room. The homeowner simply selects the fan speed, then the unit turns on and off automatically according to heating demand.

Why Beacon/Morris?

Beacon/Morris invented the concept of kickspace heaters and patented the original design. We are America's most experienced producer of kickspace heaters and build more kickspace heaters than any other manufacturer.

We make a complete range of models for every heating need, from the smallest foyer to the largest kitchen. Our new Twin-Flo III models offer important enhancements in heating capacity, quiet

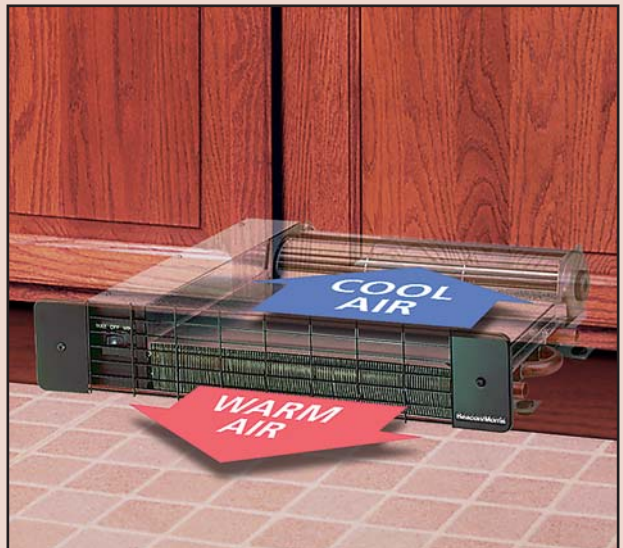

operation, appearance, and reliability. All models are designed for fast, easy installation with complete factory wiring and standardized connections. Optional kits allow for recessed mounting, surface mounting, and in-floor installation.

Go with Beacon/Morris — the **first** name in kickspace heaters.

Features & Benefits

- **Long Life** — Sealed triple ball bearing construction provides the ultimate mechanical protection for the motor and fan, ensuring years of quiet, reliable service. 
- **Space-Saving Design** — Twin-Flo III fits where standard baseboards do not. They install in the kickspace under cabinets, in between floors joists, and in tight spaces in foyers, bathrooms, finished basements, mud rooms, and more.
- **Comfort** — Twin-Flo III works with a home's hot water heating system to keep hard to heat areas warm and comfortable.
- **Made in U.S.A.** — Choose Twin-Flo III for innovative design, quality materials, and American craftsmanship. Twin-Flo III products are built with pride in the U.S.A. 
- **Quiet Operation** — Homeowners want to feel the heat — not hear it. Our exclusive sealed triple ball bearing construction makes Twin-Flo III quiet.

- **Efficiency** — To enhance heat transfer, Twin-Flo III fins are mechanically bonded to the coil. Fins are shaped and spaced to help prevent dust collection and maximize operating efficiency.
- **5 Year Warranty** — Beacon/Morris is so confident in our products we back every Twin-Flo III with a 5 year warranty. Why settle for another company's 2 or 3 year warranty? We back our products better because we make them better. 
- **Flexibility** — Homeowners don't have to have a boiler to stay warm and comfortable. Twin-Flo III units can provide spot heat using the domestic hot water heater as the source of heat. (Consult your heating contractor for installation details.)
- **Certified Performance** — Tested and certified in the United States and Canada.



Beacon/Morris Heating Products

The quality, value, and performance you expect



Slope Cabinet Unit Heater



Window Floor Vector

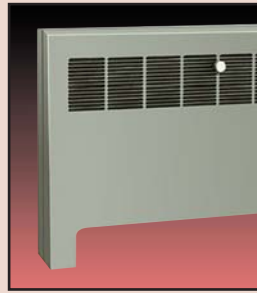

Convectors



Twin-Pak



Hot Water/Steam Unit Heaters



Vertical Unit Heater



Gas Unit Heaters



Tubular Unit Heaters



The **Twin-Flo Hose Kit** provides the installer with more flexibility in the installation of the Twin-Flo Kickspace Heaters. The tubing is flexible enough to snake around tight corners or bend around and through difficult areas like from under the floor of a house with an older basement with walls that are not exactly under the unit installation.

The kit includes a 10 foot length of flexible 1/2 inch I.D. tubing that is rated at 100 PSI at 180°F (82°C), 4 brass barbed tubing connectors (two with 1/2" male connection and 2 with 1/2" female connection) and 4 tension clamping rings.

The hose kit makes those difficult locations just a little easier to get to with fewer sweat joints to worry about.



260 North Elm Street, Westfield, MA 01085 • Tel: (413) 562-5423 • Fax (413) 572-3764
 7555 Tranmere Drive, Mississauga, Ontario L5S 1L4 Canada • Tel: (905) 672-2991 • Fax (905) 672-2883
www.beacon-morris.com



TWFII-SR

