

Pre-adjustable filling units & backflow preventer

series 553 - 573



cert. n° 0003
ISO 9001



Function

The automatic filling unit is a device consisting of a pressure reducing valve with compensating seat, an inlet filter, a shut-off valve and a check valve.

It is installed on the water inlet piping in sealed heating systems, and its main function is to maintain the pressure of the system stable at a set value, automatically filling up with water as required.

This product has the characteristic of being pre-adjustable, which means that it can be adjusted at the required pressure value before the system charging phase.

After installation, during the filling or topping-off phase, the water feed will stop when the set pressure is reached.

A pre-assembled version is also available, complete with upstream backflow preventer.



Product range

Code 553542A	Filling unit with pressure gauge and pressure setting indicator	_____	Size 1/2"
Series 573	Backflow preventer with intermediate atmospheric vent with threaded connections	_____	Size 1/2" - 3/4"
Series 573	Backflow preventer with intermediate atmospheric vent with sweat connections	_____	Size 1/2"
Code 573002A	Charging unit complete with backflow preventer 573 series with threaded connections	_____	Size 1/2"
Code 573009A	Charging unit complete with backflow preventer 573 series with sweat connections	_____	Size 1/2"

Technical specification

Filling unit

Material: Body:	brass
Cover:	PA 66 GF 30
Seals:	NBR
Maximum Working Pressure:	230 psi (16 bar)
Pressure setting range:	3÷60 psi (0.2÷4 bar)
Factory setting:	15 psi (1.035 bar)
Indicator accuracy:	±2 psi (±0.15 bar)
Maximum Working Temperature:	150°F (65°C)
Connection: Inlet:	1/2" NPT Male with union tailpiece
Outlet:	1/2" NPT Female

Backflow preventer

Material: Body:	brass
Check valve:	PSU
Check valve stem:	brass
Diaphragm:	EPDM
Seals:	EPDM
Maximum working pressure:	175 psi (12 bar)
Maximum working temperature:	210°F (99°C)
Medium:	water
Certified to:	CSA B64.3 and ASSE 1012
Connections:	1/2"-3/4" NPT female with union 1/2" sweat with union

Dimensions

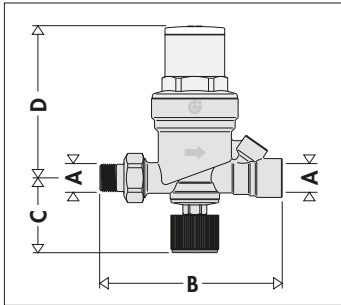

Code	A	B	C	D
553542A	1/2"	4 13/16"	1 15/16"	4"

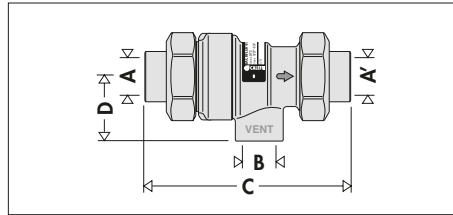

Code	A	A'	B	C	D
573403A	1/2"	1/2"	1/2"	4 1/2"	1 3/8"
573503A	3/4"	3/4"	1/2"	4 1/2"	1 3/8"
573409A	1/2" SWT	1/2" SWT	1/2"	4 7/16"	1 3/8"
573493A	1/2" SWT	1/2" NPT	1/2"	4 7/16"	1 3/8"

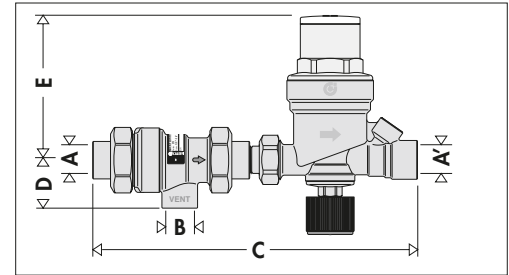

Code	A	A'	B	C	D	E
573002A	1/2"	1/2"	1/2"	9"	1 3/8"	4"
573009A	1/2" SWT	1/2" NPT	1/2"	8 15/16"	1 3/8"	4"

Construction details

Pre-calibration

This model is equipped with a pressure setting indicator for the commissioning operation. The system charge pressure can be input by means of the adjusting screw, before the start of the system charging phase.



Anti-stick materials

The central housing containing the moving parts and the internal compensating spindle are made of a low adhesion coefficient plastic. This material minimises the risk of formation of scale deposits, the main cause of malfunctions.

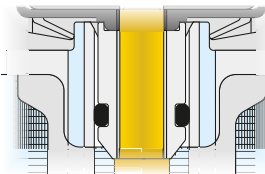

Diaphragm-seat seal

The useful working surface of the diaphragm is particularly large, in order to guarantee greater precision and sensitivity when working with minimum pressure differences.

This feature is also useful in that it gives greater power to the sliding of the spindle and overcomes friction.

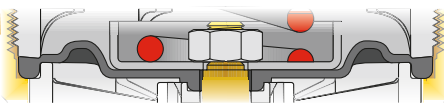

In view of the low flow rates involved, the filling unit seat has been designed with the smallest possible diameter.

This factor, combined with the extended surface of the diaphragm, creates an optimum dimensional ratio for a piece of equipment which must maintain its operating characteristics unchanged over time.

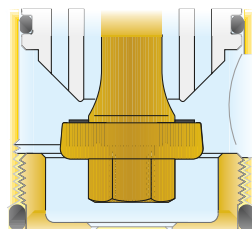

Spindle guide

In order to reduce the frictional surfaces, the spindle unit guide has been positioned in the upper part of the device.

It consists of four spokes formed directly on the plastic central support.

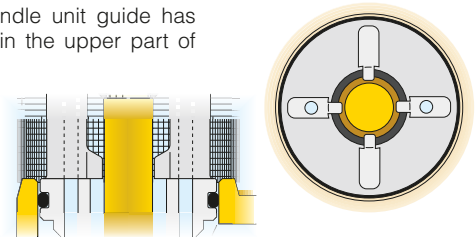

Removable filter cartridge

The cartridge containing the operating mechanisms, protected by a large surface area strainer, is removable. This makes it very easy and quick to carry out inspections, internal cleaning and even replacement of the cartridge itself.

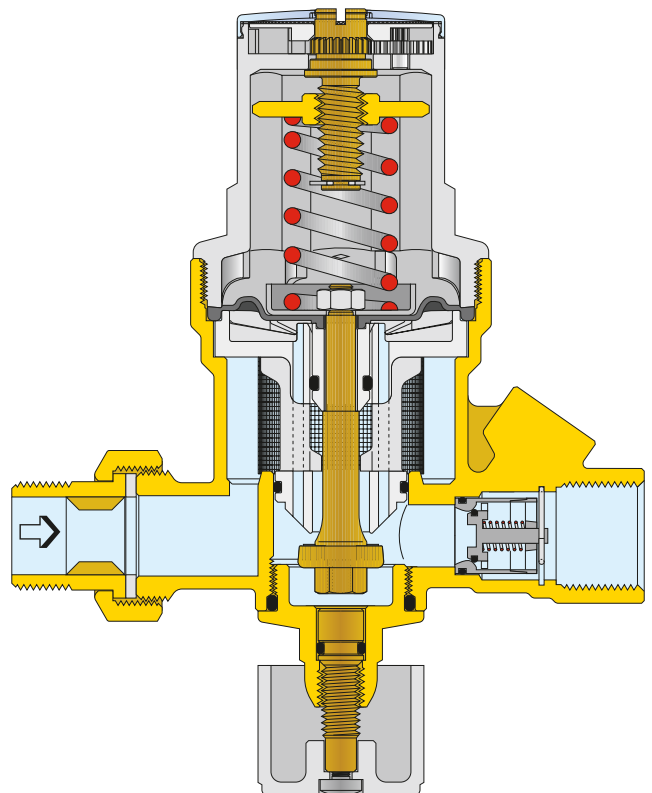

Installation

1. Filling unit can be installed in either horizontal or vertical position. It is, however, vital that the unit is not installed upside down.

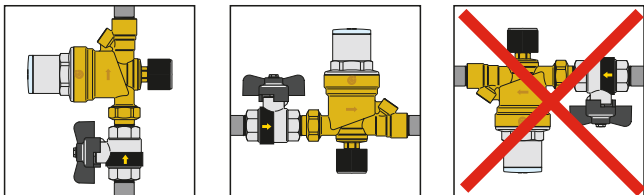

2. The special method of mechanical pre-adjustment with pressure setting indicator makes it possible to set the unit to the required value in the system before the beginning of the filling phase.

3. The unit is normally set at a pressure not less than that obtained by adding the hydrostatic pressure and 4 psi (0,3 bar).

4. During filling, the internal mechanism will automatically regulate the pressure until it reaches the required value, **without the need to oversee the filling operation** itself. This prevents the system being charged to a higher pressure than required.

5. Given the pre-calibrating function, the presence of the downstream pressure gauge is not essential.

6. When the system is filled, the shut-off valve can be closed. In order to restore the automatic topping-off condition, merely re-open the valve. The pressure in the system will gradually return to the set pressure.

Maintenance

For cleaning, inspection or replacement of the entire cartridge, proceed as follows:

1. Isolate the unit.
2. Open the lower control knob.
3. Unscrew the adjusting screw until it stops.
4. Remove the upper cover.
5. Extract the cartridge using pliers.
6. The entire unit, after inspection, can be reassembled or replaced using a spare cartridge.
7. Re-adjust the equipment.

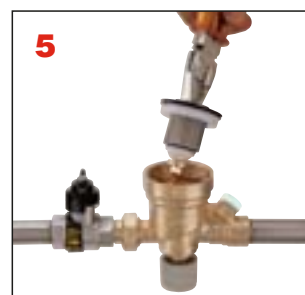
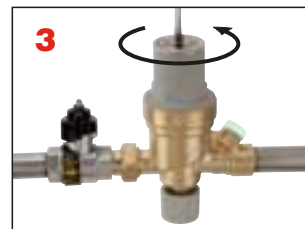
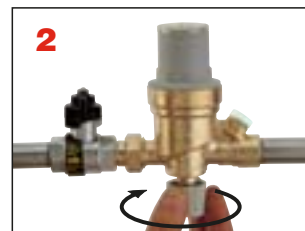

Backflow preventer

The backflow preventer with atmospheric vent is designed to protect drinking water systems from the return, caused by backsiphonage or backpressure, of contaminated fluids.

The Caleffi 573 series has been specifically certified to standards CSA B64.3 and ASSE 1012.

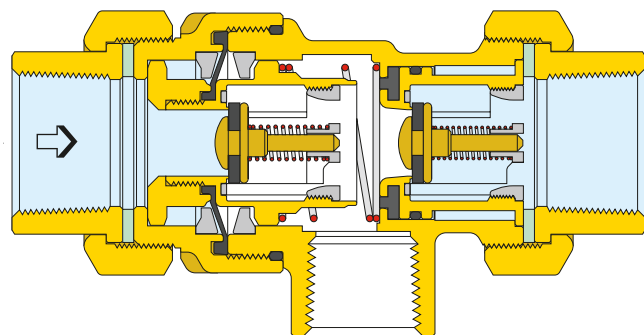

VENT

Flow rate graph

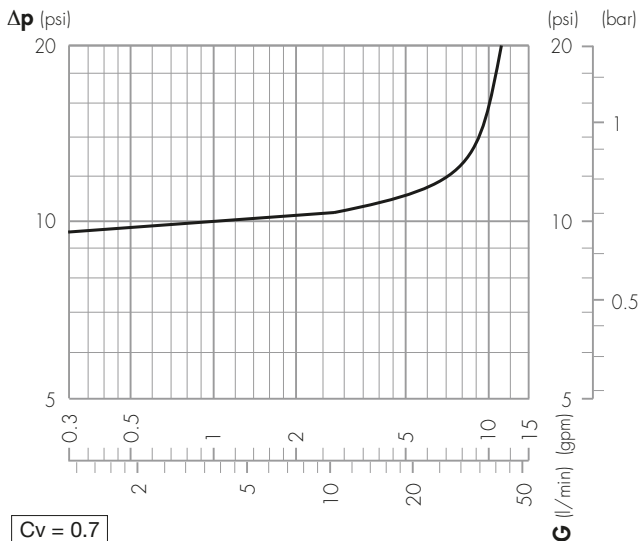

Code 573002A - 573009A

Charging unit consists of:

- Backflow preventer with intermediate atmospheric vent, 573 series
- Filling unit, 553 series

Application diagram

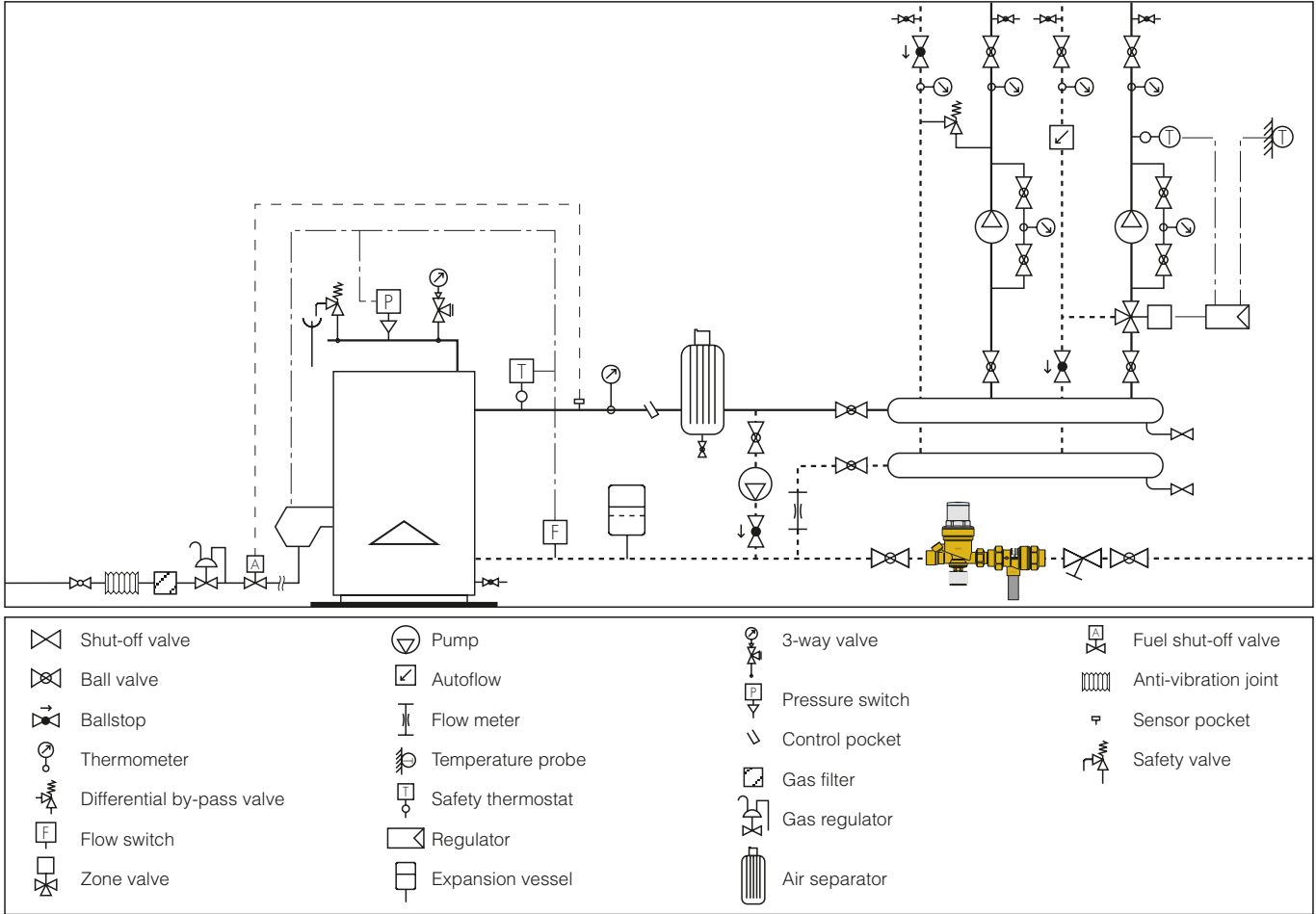

SPECIFICATION SUMMARIES

Code 553542A

Filling unit with pressure gauge connection and pressure setting indicator. 1/2" NPT Male with union x Female threaded connection. Brass body. Nylon plastic cover. Sliding surfaces in anti-stick plastic. Diaphragm and seals in NBR. Cartridge removable for maintenance operations. Maximum working temperature 150°F. Maximum inlet pressure 230 psi. Setting range 3÷60 psi. Pressure indicator for pre-adjustment of device, accuracy ±2 psi. Complete with isolating valve, filter and check valve.

Series 573

Backflow preventer with atmospheric vent. Certified to CSA B64.3 and ASSE 1012. 1/2" (3/4") NPT female threaded connection with union or 1/2" sweat with union. Brass body, check valve in PSU, diaphragm and seals in EPDM. Maximum working pressure 175 psi. Maximum working temperature 210°F.

Code 573002A - 573009A

Charging unit complete with backflow preventer 1/2" NPT Female threaded with union or 1/2" sweat with union inlet connection and 1/2" NPT Female threaded outlet connection. Maximum working temperature 150°F. Maximum inlet pressure 175 psi.

We reserve the right to change our products and their relevant technical data, contained in this publication, at any time and without prior notice.



Caleffi North America, Inc.
 Corporate Headquarter & Production
 9850 South 54th Street / Milwaukee, WI 53132
 Tel: 414.421.1000 / Fax: 414.421.2878 / www.caleffi.com
 © Copyright 2003 Caleffi North America, Inc.